

SELECTION GUIDE

Order code	Input Voltage (V)	Output Voltage1 (V)	Output Voltage2 (V)	Output Current1 (MA)	Output Current2 (MA)	Efficiency (%)	MTTF ¹ (KHRS)
D050503XD	5	5	3.3	100	152	70	1615
D050505XD	5	5	5	100	100	70	1615
D050509XD	5	5	9	100	56	80	669
D050512XD	5	5	12	100	42	80	339
D050515XD	5	5	15	100	34	80	187
D050503XS	5	5	3.3	100	152	70	1615
RD050505XS	5	5	5	50	50	70	146
D050505XS	5	5	5	100	100	70	1615
D050509XS	5	5	9	100	56	80	669
D050512XS	5	5	12	100	42	80	339
D050515XS	5	5	15	100	34	80	187
D120505XD	12	5	5	100	100	70	489
D120509XD	12	5	9	100	56	80	343
D120512XD	12	5	12	100	42	80	229
D120515XD	12	5	15	100	34	80	148

OUTPUT CHARACTERISTICS

Parameter	Conditions	Min.	Typ.	Max.	Units
Rated Power ¹	TA=-40°C to 120°C			1	W
Voltage Set Point Accuracy	See tolerance envelope				
Line regulation	D050503X(S)D (High Vin to low Vin)		1.0	1.25	%%
	All other variants (High Vin to low Vin)		1.0	1.20	%%
Load regulation ²	10% load to rated load, 3.3V output types			15	%
	10% load to rated load, 5V output types			15	%
	10% load to rated load, 9V output types			10	%
	10% load to rated load, 12V output types			10	%
	10% load to rated load, 15V output types			10	%
Ripple and Noise	BW=DC to 20MHz, All output types			75	mVp-p

ISOLATION CHARACTERISTICS

Parameter	Conditions	Min.	Typ.	Max.	Units
Isolation test voltage	Flash tested for 1 second	1000			VDC
Resistance	Viso=500VDC	1			GΩ

GENERAL CHARACTERISTICS

Parameter	Conditions	Min.	Typ.	Max.	Units
Switching frequency	All input types		100		kHz

TEMPERATURE CHARACTERISTICS

Parameter	Conditions	Min.	Typ.	Max.	Units
Specification	All output types	0		70	°C
Storage		-55		150	°C
Cooling	Free air convection				

TEMPERATURE DERATING GRAPH

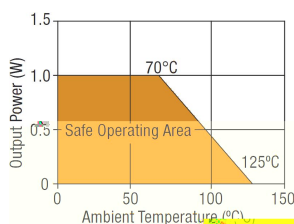

TOLERANCE ENVELOPE

D-X(S)D

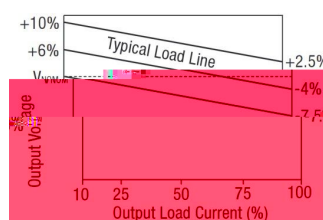

1. See derating graph.

2. See derating curve.

All specifications typical at TA=25°C, nominal input voltage and rated output current unless otherwise specified. Another 24V & 48V products, please inquire Our technical department!

TECHNICAL NOTES

ISOLATION VOLTAGE

"Hi Pot Test", "Flash Tested", "Withstand Voltage", "Dielectric Withstand Voltage" & " Isolation Test Voltage" are all terms that relate to the same thing, a test voltage. Applied for a specified time, across a component designed to provide electrical isolation, to verify the integrity of that isolation. Professional Power Module D-X(S)D series of DC/DC converters are all 100% production tested at their stated isolation voltage. This is 1KVDC for 1 second.

A question commonly asked is, "What is the continuous voltage that can be applied across the part in normal operation?"

For a part holding no specific agency approvals, such as the D-X(S)D series ,both input and output should normally be maintained within SELV limits i.e. less than 42.4V peak, or 60VDC. The isolation test voltage represents a measure of immunity to transient voltages and the part should never be used as an element of a safety isolation system. The part could be expected to function correctly with several hundred volts offset applied continuously across the isolation barrier, but then the circuitry on both sides of the barrier must be regarded as operating at an unsafe voltage and further isolation/insulation systems must form a barrier between these circuits and any user accessible circuitry according to safety standard requirements.

REPEATED HIGH-VOLTAGE ISOLATION TESTING

It is well known that repeated high-voltage isolation testing of a barrier component can actually degrade isolation capability, to a lesser or greater degree depending on materials. Construction and environment. The D-X(S)D series has toroidal isolation transformers, with no additional insulation between primary and secondary windings of enameled wire. While parts can be expected to withstand several times the stated test voltage, the isolation capability does depend on the wire insulation. Any material, including this enamel (typically polyurethane) is susceptible to eventual chemical degradation when subject to very high applied voltages thus implying that the number of tests should be strictly limited. We therefore strongly advise against repeated high voltage isolation testing, but if it is absolutely required, that the voltage be reduced by 20% from specified test voltage. This consideration equally applies to agency recognized parts for better than functional isolation where the wire enamel insulation is always supplemented by a further insulation system of physical spacing or barriers.

OUTPUT RIPPLE REDUCTION

By using the values of inductance and capacitance stated, the output ripple at the rated load is lowered to 5mV p-p max.

Component selection

Capacitor: Ceramic chip capacitors are recommended. It is required that the ESR(Equivalent Series Resistance)should be as low as possible.X7R types are recommended. The voltage rating should be at least twice(except for 15V output),the rated output voltage of the DC/DC converter.

Inductor: The rated current of the inductor should not be less than of the output of the DC/DC converter. At the rated current, the DC resistance of the inductor should be such that the voltage drop across the inductor is <2% of the rated voltage of the DC/DC converter. The SRF(Self Resonant Frequency) should be >20MHz.

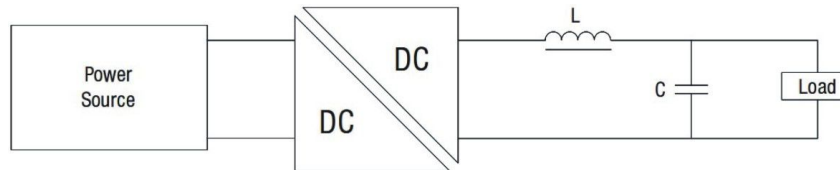

OUTPUT RIPPLE REDUCTION

Ripple&Noise Characterisation Method

Ripple and noise measurements are performed with the following test configuration.

C1	1uF X7R multilayer ceramic capacitor, voltage rating to be a minimum of 3 times the output voltage of the DC/DC converter
C2	10uF tantalum capacitor, voltage rating to be a minimum of 1.5 times the output voltage of the DC/DC converter with an ESR of less than 100mΩ at 100 KHz
C3	100nF multilayer ceramic capacitor, general purpose
R1	450 Ω resistor, carbon film, ±1% tolerance
R2	50 Ω BNC termination
T1	3T of the coax cable through a ferrite toroid
RLOAD	Resistive load to the maximum power rating of the DC/DC converter. Connections should be made via twisted wires

Measured values are multiplied by 10 to obtain the specified values.

Differential Mode Noise Test Schematic

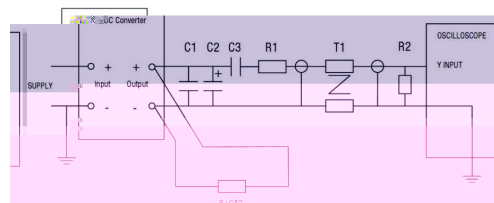

PACKAGE SPECIFICATIONS

MECHANICAL DIMENSIONS

DIP package

SIP package

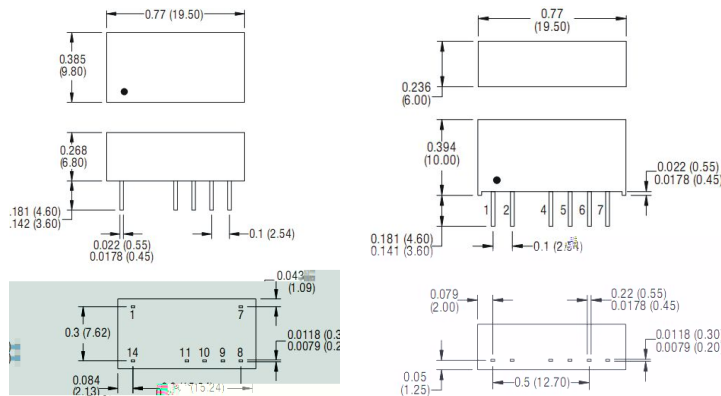

All dimensions in inches ± 0.01 (mm ± 0.25 mm). All pins on a 0.1 (2.54) pitch and within ± 0.01 (0.25) of true position.

PIN CONNECTIONS

PIN CONNECTIONS-14 PIN DIP

pin	Function
1	-VIN
7	NC
8	-VOUT2
9	+VOUT2
10	-VOUT1
11	+VOUT1
14	+VIN

PIN CONNECTIONS-7 PIN SIP

pin	Function
1	+VIN
2	-VIN
4	+VOUT1
5	-VOUT1
6	+VOUT2
7	-VOUT2

NC - Not available for electrical connection.

RECOMMENDED FOOTPRINT DETAILS

14 Pin DIP Package

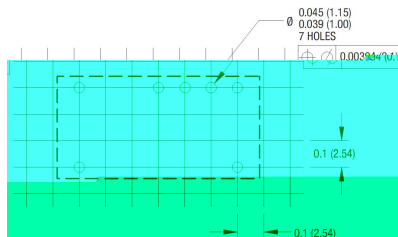

7 Pin SIP Package

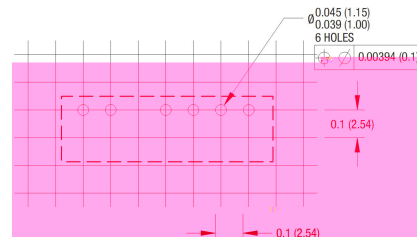

Unless otherwise stated all dimensions in inches ± 0.01 (mm ± 0.25 mm).

TUBE OUTLINE DIMENSIONS

14 Pin DIP Tube

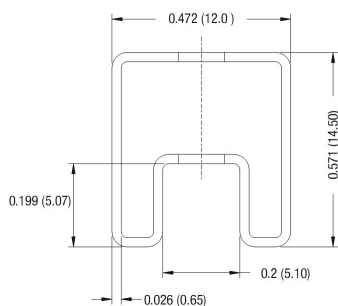

7 Pin SIP Tube

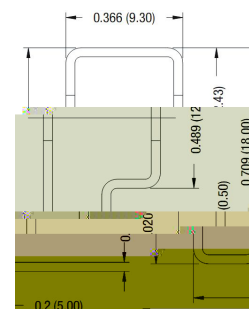

Unless otherwise stated all dimensions in inches ± 0.02 (mm ± 0.5 mm).

Tube length (14 Pin DIP) : 20.47 (520mm ± 2 mm).

Tube length (7 Pin SIP) : 20.47 (520mm ± 2 mm).

Tube Quantity :25